

RTH

17.127



CONSTRUCTION



LOGISTICS



EVENTS AND
FILM



RTH 17.127



CAB

Best-in-class
safety and visibility



PERFORMANCE

Unrivaled lifting
performance



LOAD LIVE DIAGRAM

Three real-time dynamic
load charts

DIMENSIONS (ft and in)

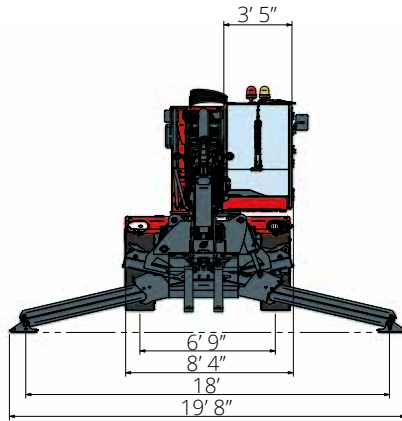

FRONT
view

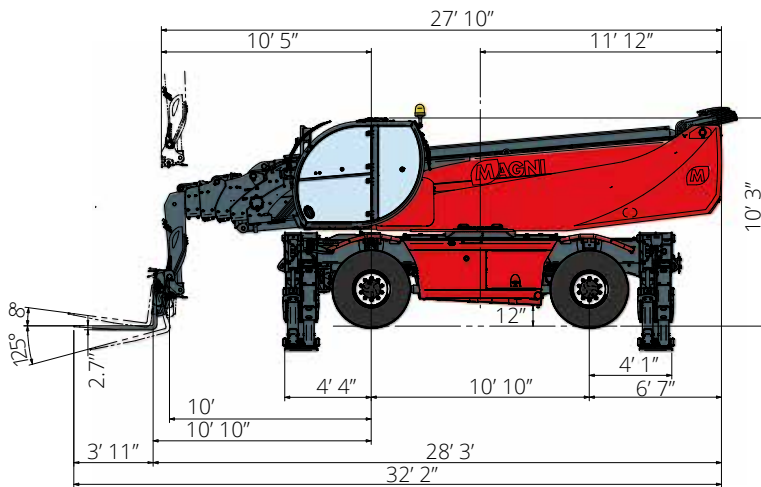

SIDE
view

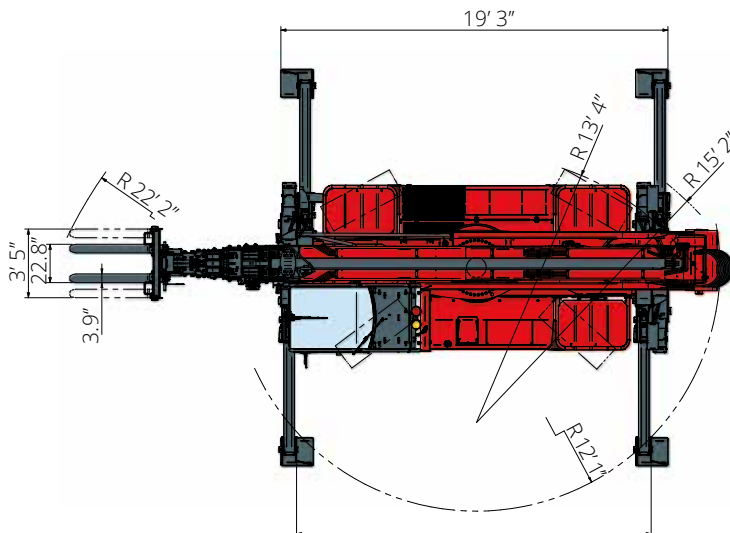

TOP
view

Load chart with
FULLY EXTENDED STABILIZERS (360°) - M1
 ATT - 03 - 007

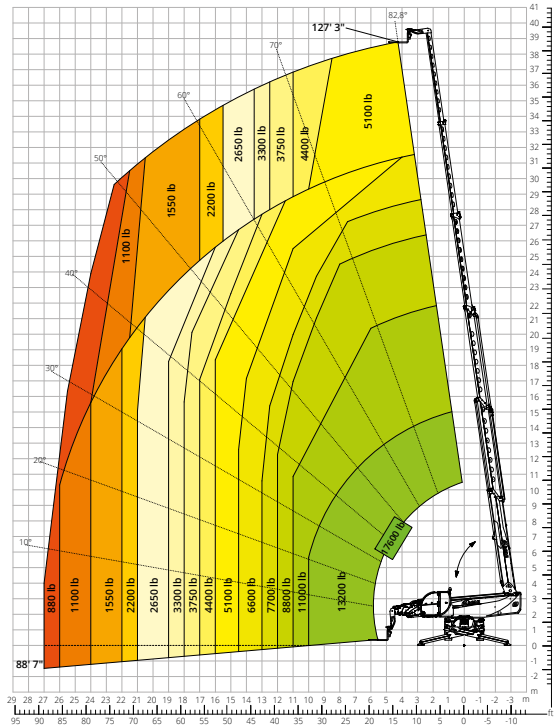

Load chart with
FULLY EXTENDED STABILIZERS (360°) - M2
 ATT - 03 - 007

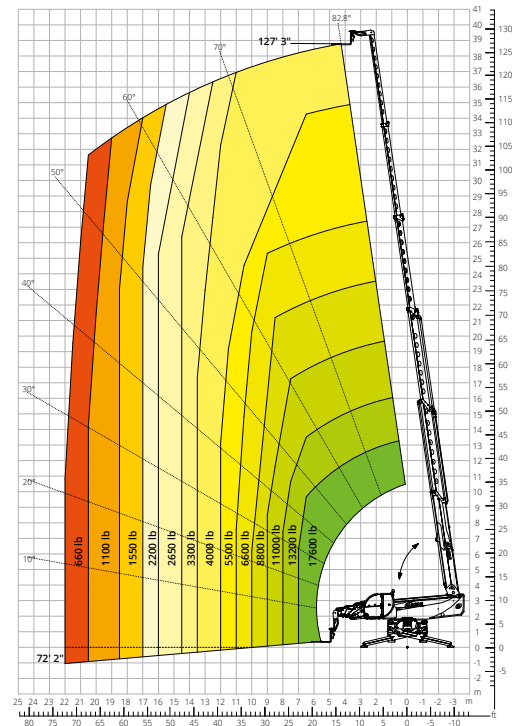

Load chart
FRONT ATTACHMENT ON TIRES
 ATT - 08 - 001

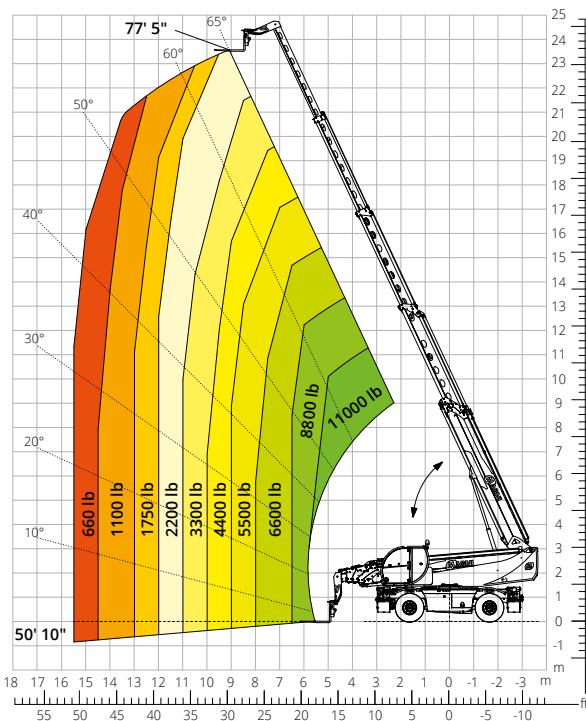

Load chart with
WINCH, 17,600 lb - M1
 ATT - 02 - 006

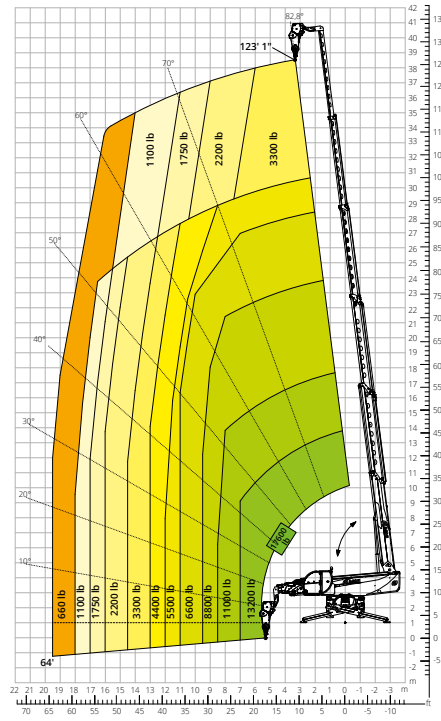

Load chart with
JIB WITH WINCH, 3,300 lb
 ATT - 08 - 001

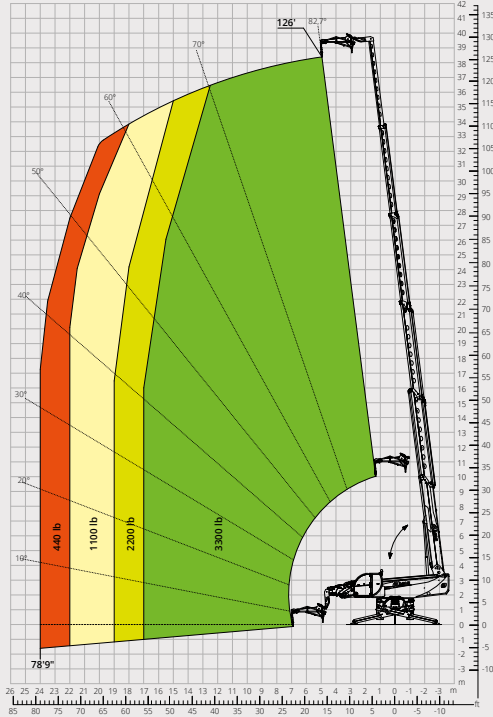

Load chart with
JIB WITH WINCH, 5,950 lb
 ATT - 04 - 017

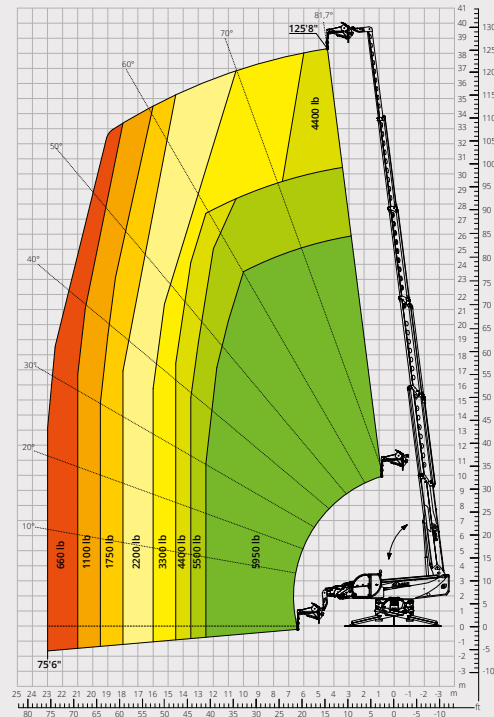

Load chart with
HOOK, 17,600 lb - M1
 ATT - 05 - 003

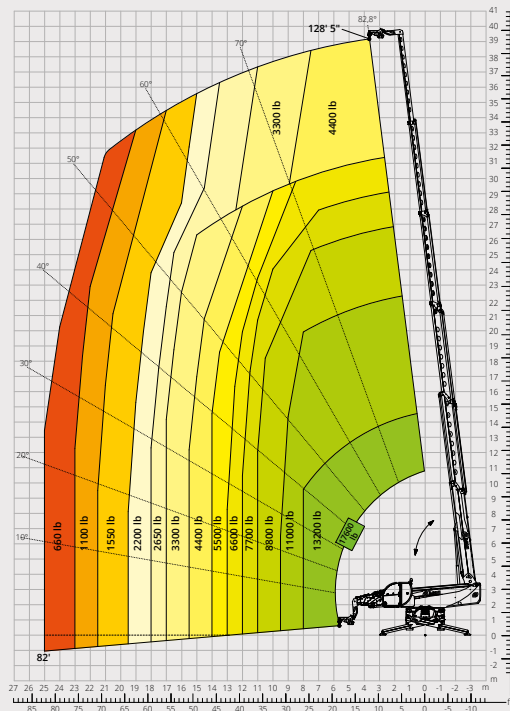

Load chart with
JIB, 4,400 lb
 ATT - 04 - 013

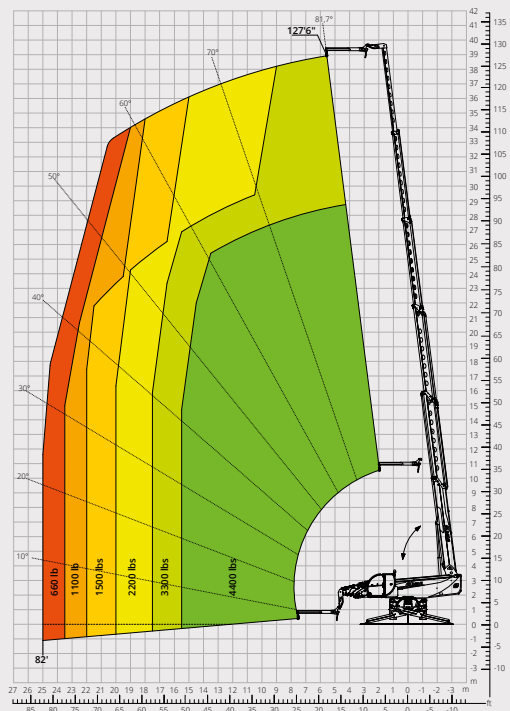

Load chart with
ROTATING EXTENDABLE PLATFORM, 1,100 lb
ATT - 01 - 005

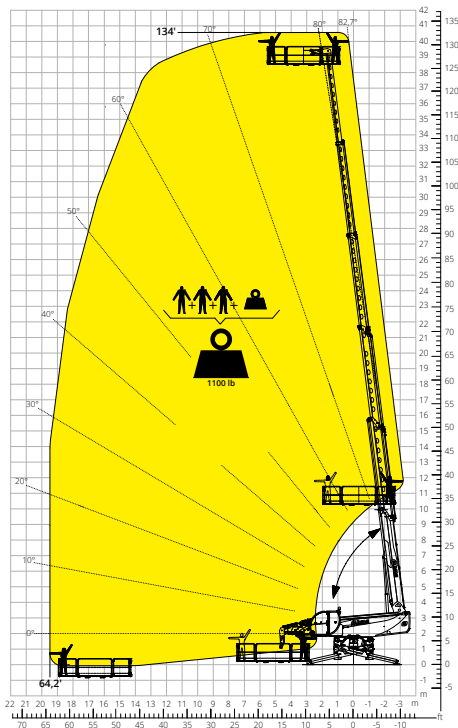

Load chart with
PLATFORM, 1,100 lb, WITH WINCH, 1,300 lb
ATT - 01 - 026

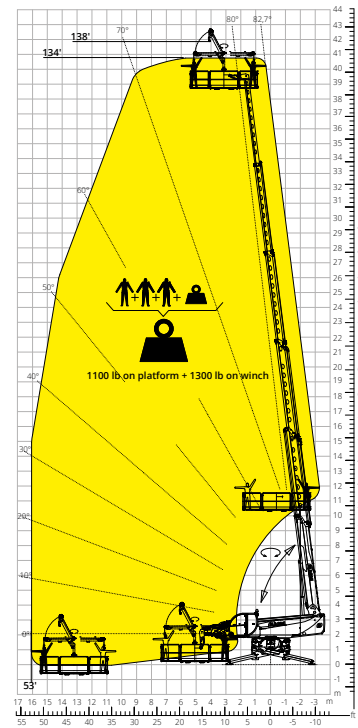

Load chart with
OVER-UNDER PLATFORM - POSITIVE
ATT - 01 - 024

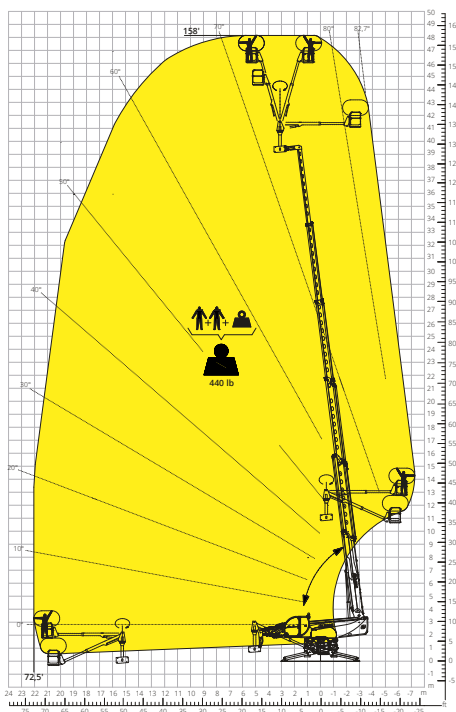

Load chart with
OVER-UNDER PLATFORM - NEGATIVE
ATT - 01 - 024

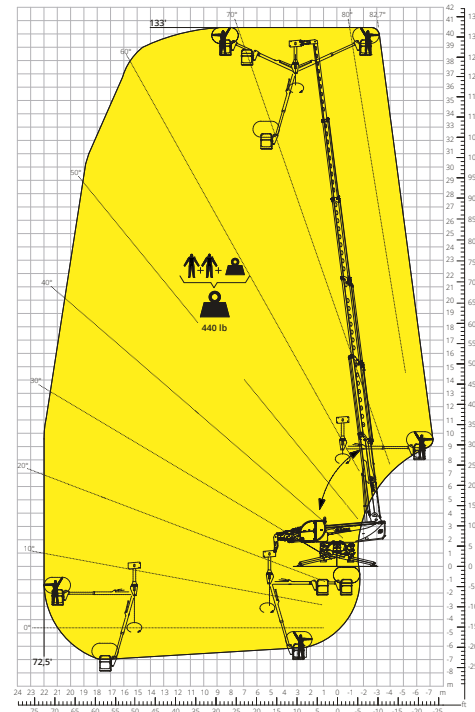

	Rotating telescopic handler	RTH 17.127	
Machine model	Maximum lifting capacity	17,600 lb	
	Maximum lifting height	127' 3"	
	Maximum reach	88' 6"	
	Rotation	360° (continuous)	
Stabilizers	Type	Telescopic scissor	
Engine	Model	Volvo TAD 552 VE Stage IIIA	Volvo TAD 583 VE Stage V
	Rated power	160 kW (218 hp) at 2,200 rpm	175 kW (238 hp) at 2,300 rpm
	Maximum torque	671 lb/ft at 1,450 rpm	719 lb/ft at 1,380 rpm
	Displacement	313 in ³	
	Cylinders	4 in line	
	Engine type	Turbocharged direct injection diesel	
	Cooling system	Water - intercooler	
Transmission	Type	Hydrostatic	
	Maximum pressure	480 bar	
	Gearbox	Dropbox, 2 speeds forward-reverse	
Axles and brakes	Type	Axles with planetary gearboxes	
	Front axle	Oscillating and steering with levelling, +/-8°	
	Rear axle	Oscillating and steering with hydraulic lock	
	No. of steering wheels	4WD - 4WS	
	Steering mode	Frontal/Concentric/Crab	
	Service brake	Wet multi-disk on front and rear axle	
	Parking brake	Hydraulic with negative action on front axle	
Performance	Tyre sizes	445/65 R22.5	
	Max. travel speed	25 mph	
	Gradeability (unladen)	66%	
Weights	Turning radius (at forks)	22' 2"	
	Total unladen*	52,900 lb	
Tank and system capacities	Diesel fuel	74 U.S. gal	74 U.S. gal
	AdBlue	-	10.56 U.S. gal
	Hydraulic fluid	71.1 U.S. gal	71.1 U.S. gal
	Engine oil	4.22 U.S. gal	4.22 U.S. gal
	Coolant	10.56 U.S. gal	10.56 U.S. gal
Hydraulic circuit for movements	Circuit type	Load sensing	
	Service pump	Variable displacement	
	Max. hydraulic flow rate	54.2 U.S. gpm	
	Max. boom head flow rate	19.8 U.S. gpm	
	Max. working pressure	350 bar	
	Distributor for boom and turret movements	SIL 2 electro-proportional valve	
Standards met	Movements control	Dual joystick with integrated manoeuvre enable	
		2006/42/EC: EU Machinery Directive	
		2016/1628: EU Regulation on the emissions of stage V engines	
		EN 1459-X: Relating to standards on the safety requirements for variable reach machines	
		EN 280-1/EN 280-2: standards relating to mobile elevating work platforms (if available)	
	ROPS/level 2 FOPS: relating to the standards for protective structures		

The data given in this brochure are provided for information purposes and are subject to change without prior notice.
 All images are purely guideline and might not give an exact representation of the product.
 *the stated weight refers to the vehicle unladen with standard equipment and may vary depending on the chosen configuration.

The standard machine configuration includes:

CAB

- “Easy access” system
- Premium tilting seat with air suspension and headrest
- Adjustable steering column
- Analogue joypad
- Adjustable sunblind
- Heating
- Air conditioning
- FM/AM radio with USB and Bluetooth connectivity
- Ambient LED lights
- USB Type-A and Type-C (5 V) inputs

REAL TIME INFORMATION

- Touchscreen, 12”
- MCTS – Magni Combi Touch System on-board software
- Automatic RFID tools recognition system
- LMI – Load Moment Indicator
- LLD – Live Load Diagram
- Onboard and remote integrated diagnostics
- Reversing camera with image integrated in the MCTS

TECHNICAL SPECIFICATIONS

- Q-Fit standard
- Provision for platform
- Advanced three-line CAN BUS system
- Automatic levelling system for outriggers
- Automatic front and rear wheel alignment
- High-precision turret rotation motor by Liebherr
- Automatic parking brake
- Mechanical battery cut-off in engine compartment
- Electrical system: 24 V – IP67

SERVICE

- MyMagni by Trackunit connectivity system (free of charge on request)
- Warranty: 24 months/2,000 hours