

THA

11.25

PRELIMINARY

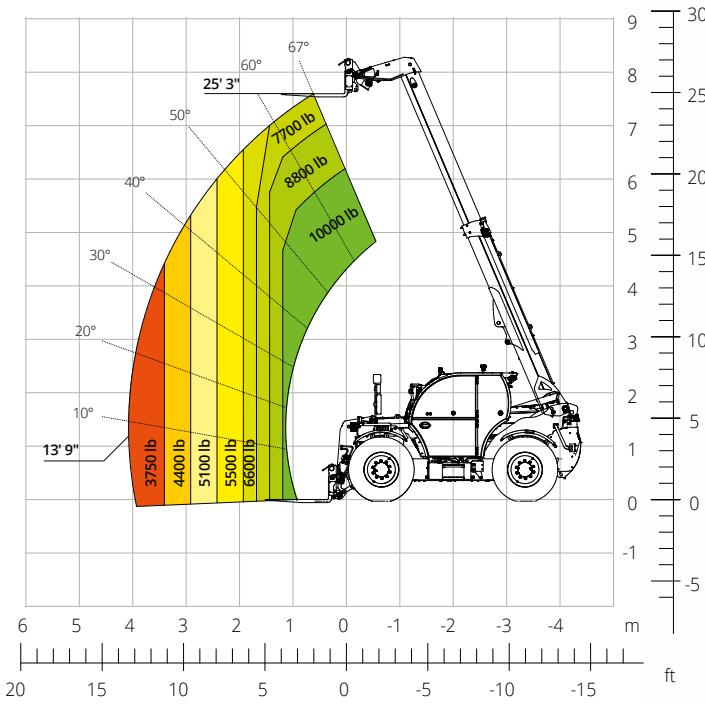

AGRICULTURE

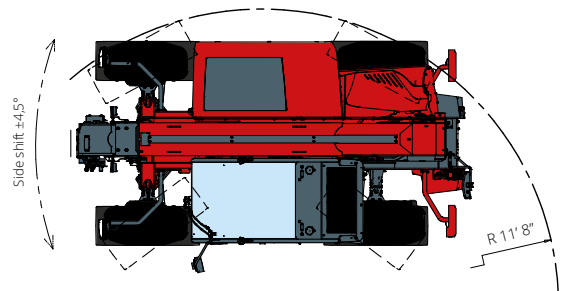
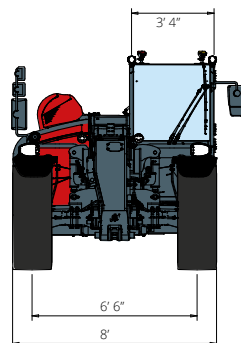
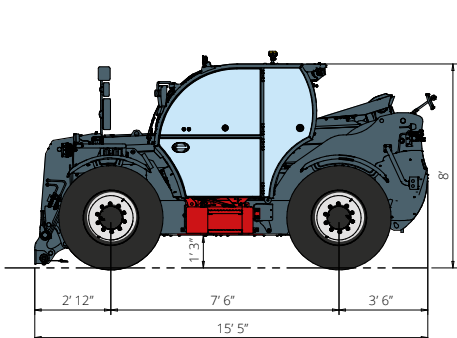

Machine model	Telescopic handler	THA 11.25
	Maximum lifting capacity	11,000 lb
	Maximum lifting height	25' 3"
	Maximum reach	13' 9"
Engine	Model	FPT N45 Stage V
	Rated power	125 kW (170 hp) at 2,200 rpm
	Maximum torque	525 lb/ft at 1,500 rpm
	Displacement	274.6 in ³
	Cylinders	4 in line
	Engine type	Turbocharged direct injection diesel
	Cooling system	Water – intercooler
Transmission	Type	CVT – 2M
	Maximum pressure	480 bar
	Gearbox	CVT 2 speeds forward and reverse
Axles and brakes	Type	Axles with planetary gearboxes
	Front axle	Steering, oscillating only with suspensions activated with levelling, +/-7°
	Rear axle	Steering, oscillating only with suspensions deactivated with hydraulic lock
	Sideshift	±4.5°
	No. of driving wheels - steering wheels	4WD - 4WS
	Steering modes	Frontal/Concentric/Crab
	Service brake	Wet multi-disk on front and rear axle
	Parking brake	Hydraulic with negative action on front and rear axles
	Tyre sizes	460/70 R24
	Performance	Max. travel speed
Turning radius (over tyres)		12' 14"
Tractive effort		10,800 daN
Weights	Total unladen*	20,300 lb
Tank and system capacities	Diesel fuel	34 U.S. gal
	AdBlue	5.3 U.S. gal
	Hydraulic fluid	34 U.S. gal
	Engine oil	3 U.S. gal
	Coolant	7.9 U.S. gal
Hydraulic circuit for movements	Circuit type	Electronic load sensing
	Service pump	Variable displacement
	Max. hydraulic flow rate	43.6 U.S. gpm
	Max. boom head hydraulic flow rate	26.4 U.S. gpm
	Max. working pressure	350 bar
	Distributor for boom movements	Compensated electro-proportional valve
Road type approval	167/2013: Mother Regulation	T1b
Standards met	2006/42/EC: EU Machinery Directive 2000/14/EC: Noise Directive EN 1459-1: relating to standards on the safety requirements for variable-reach trucks EN 280-1: standards relating to mobile elevating work platforms (if available) 2014/30/EU: EMC Directive ROPS/level 2 FOPS: relating to the standards for protective structures	

The data given in this brochure are provided for information purposes and are subject to change without prior notice.
 All images are purely guideline and might not give an exact representation of the product.

*the stated weight refers to the vehicle unladen with standard equipment and may vary depending on the chosen configuration.