



ES0707DC

Paved surface scissor lift

STANDARD EQUIPMENT

- Automatic tipping protection system underneath body
- Self-locking door on platform
- Speed limit at full height
- Platform load sense system
- Drivable at full height
- Automatic braking system
- Non-marking tyres
- Tilt indicator with alarm
- Warning siren during lowering and dual flashing LED light
- Safety bracket for maintenance operations
- Horn
- Emergency stop button
- Emergency lowering system
- Anchoring eyebolts
- On-board diagnostics system
- Hour counter
- Proportional controls
- Fold-down guardrails
- Maintenance free battery
- Explosion-proof tubing system
- Motion alarm
- Integral front and side holes for forklift transportation
- Charging protection system
- Charge level gauge
- Tie-down and lifting points
- Unidirectional platform extension
- Two-wheel drive
- Two-wheel steering
- Manual emergency brake release



LOGISTICS



CONSTRUCTION

ES0707DC

Load capacity		230 kg
Load capacity on extended platform		113 kg
Max. occupants (inside/outside)		2/1
Max. working height	A	6.50 m
Platform floor level height	B	4.50 m
Overall length	C	1.58 m
Overall width	D	0.76 m
Overall height (rails up)	E	2.05 m
Transport height (rails down)	F	1.68 m
Platform dimensions (length/width)		1.44 m / 0.74 m
Platform extension	G	0,60 m
Ground clearance (stowed)		0.07 m
Ground clearance (raised)		0.016 m
Wheelbase	H	1.12 m
Turning radius (inside)		0 m
Turning radius (outside)		1.30 m
Driving motors		2x24VDC/0.5kW
Lifting motors		24VDC/2.2kW
Travel speed (stowed)		4.5 km/h
Travel speed (raised)		0.6 km/h
Batteries		AGM batteries Maintenance-free 24V/115Ah
Hydraulic tank		3.5 l
Integrated battery charger		24V/15A
Gradeability		25%
maximum working slope		1.5°/3°
Non-marking tyres		305x100 mm
Weight (CE)		1,200 kg



Non-marking solid tyres



Safety bracket

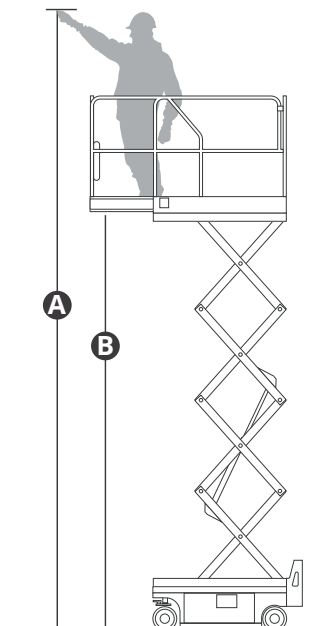
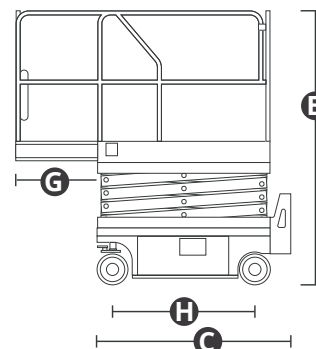
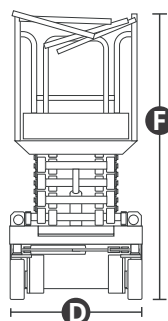

STANDARDS MET: EN 280-1, ANSI/SAIA A92.20

The data given in this brochure are provided for information purposes and are subject to change without prior notice. All images are purely guideline and might not give an exact representation of the product.